

STANDARD
 MODEL NO. MHC-D5-12000
 CUSTOMER APPROVAL DRAWING

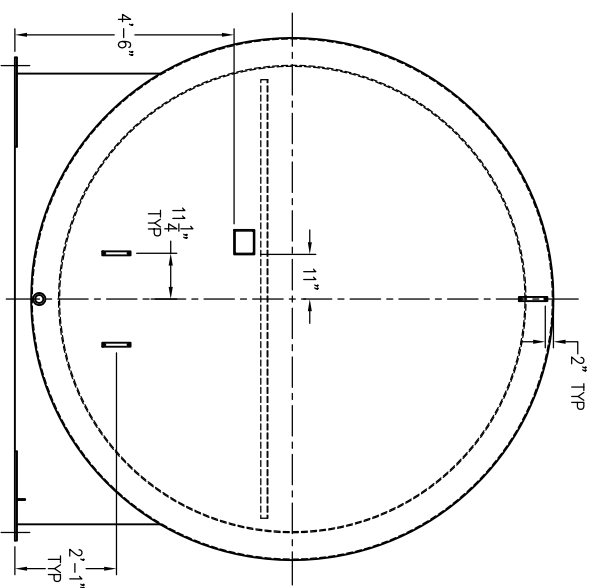

LEFT END VIEW

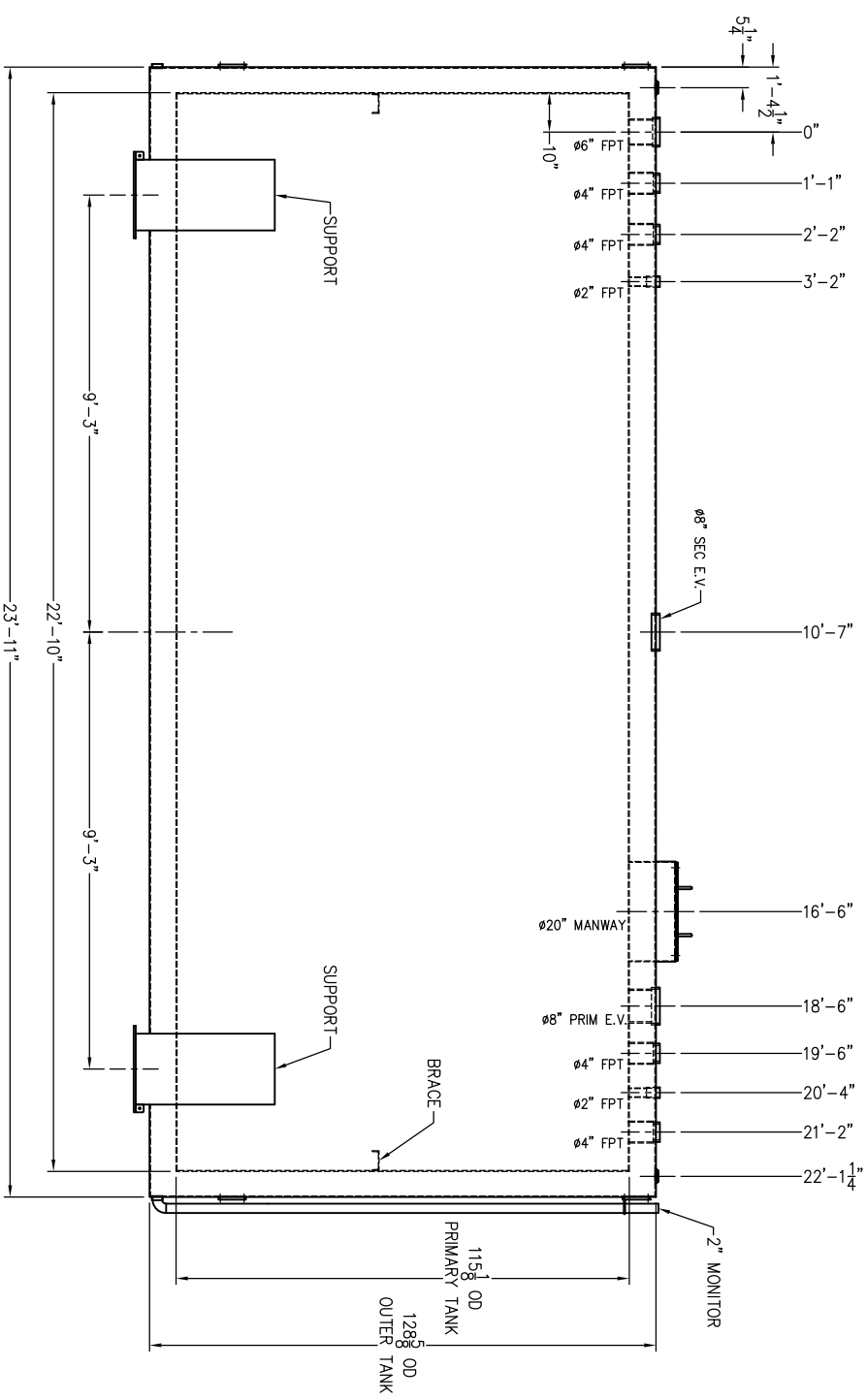

ELEVATION VIEW

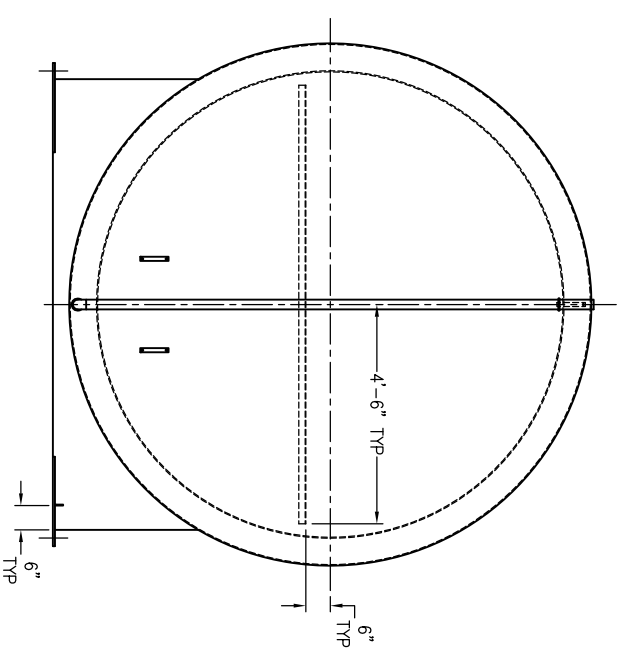

RIGHT END VIEW

CUSTOMER APPROVAL: _____

DATE: _____

SHOP ORDER NO.: _____

EST. STEEL TANK WEIGHT: _____

VENTING CAPACITY

PRIMARY: 404,000 SCFH

SECONDARY: 442,700 SCFH

modern custom fabrication
 fresno california
 P.O. Box 11925 • 2421 E. California Ave. • Fresno, California 93721
 Ph: (559) 264-4741 OR 800-800-TANK • Fax: (559) 237-3413



Prepared for
 SUPERVAULT MH-PROTECTED ABOVE GROUND STORAGE TANK

MODEL NO. MHC-D5-12000

DRAWN BY: JJK	SCALE: NTS	SHT. 1 OF 1
CHECKED BY: _____	DATE: --	
DWG./JOB NO.:		